

PHOTOELECTRIC BEAM SENSOR

(TWIN BEAM)

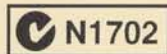

PB-30TK(K)/(W) · PB-60TK(K)/(W)



Outdoor 100ft.(30m)
Indoor 200ft.(60m)

Outdoor 200ft.(60m)
Indoor 400ft.(120m)



Black housing : PB-30/60TK(K)

White housing : PB-30/60TK(W)

Patent pending : 1
Utility model registered : 1
Utility model pending : 1
Design registered : 1



Pole mount

The TAKEX "TWIN" photoelectric beam is designed to meet the highest standards of quality and reliability for photoelectric beam intrusion detection. Unique twin beams are synchronized to work together to reinforce the range and stability in severe weather conditions. The system has a rotary optical system for easy installation and the special lens design aids in proper alignment.

HIGH RELIABILITY

Synchronized twin beams reduce false alarms caused by flying birds and falling leaves.

EXTERNAL LIGHT PROTECTION

Trouble-free condition in 50,000 lx illumination fluctuation is assured by external light compensation circuit a filter, specially designed, that cuts visible rays effectively. Excellent tolerance against sun light, automobile head light, fluorescent light or mercury light.

EASY BEAM ALIGNMENT

The special view finder allows for fast aiming and assures good alignment. Equipped with monitor jack to check sensitivity.

ROTARY OPTICAL SYSTEM

The optical system of both the transmitter and receiver can be rotated a full 180° which allows for side aiming. Therefore the units do not have to be mounted face to face and the beam direction can not be discerned by simple observation.

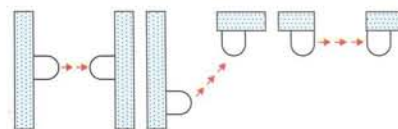

INSECT PROTECTION

A sealed optical system prevents intrusion and interference by insects.

OTHER FEATURES

- * Automatic Gain Control circuit loaded
- * Wide adjustment (horizontally $\pm 90^\circ$, vertically $\pm 10^\circ$)
- * Two different colors housing (Black/White)

PROTECTION AGAINST FROST/DEW

As a special hood is attached on sensor cover, beam protection continues without interruption even when the cover is screened by frost or dew.

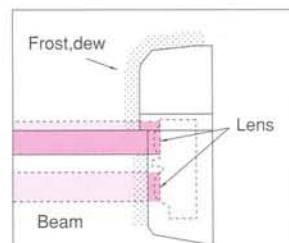

PHOTOELECTRIC BEAM SENSOR

COVERAGE



PB-30TK:Outdoor	100ft. (30m)
Indoor	200ft. (60m)
PB-60TK:Outdoor	200ft. (60m)
Indoor	400ft. (120m)

OPTIONAL

- Pole
KP-100 (100cm, 2pcs./set)
KP-150 (150cm, 2pcs./set)



- Pole cover (2pcs./set)
BP-60TE
(pole cap, screw included)



- Housing case
KH-120



- Pole attachment (2pcs./set)
BP-60A



TERMINAL ARRANGEMENT

[Transmitter]

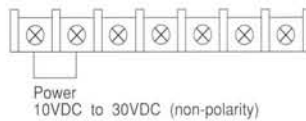

[Receiver]

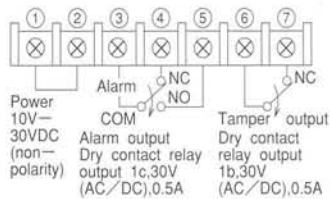

EXTERNAL DIMENSIONS

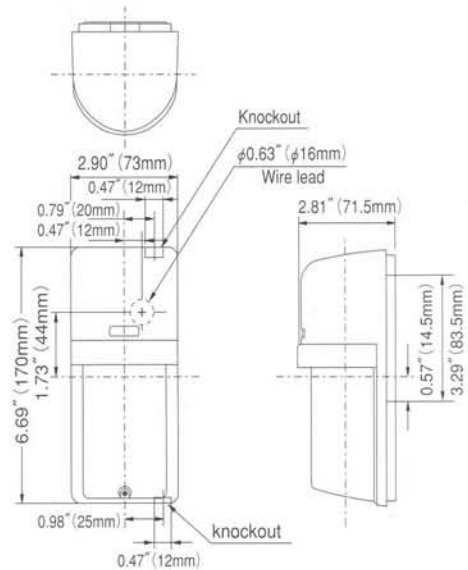

SPECIFICATIONS

The specifications are subject to change without notice.

Model	PB-30TK(K)/(W)	PB-60TK(K)/(W)
Detection system	Simultaneous breaking, of 2 beams	
Infrared beam	LED pulsed beam Double modulation	
Protection distance	Outdoor 30m (100') or less Indoor 60m (200') or less	Outdoor 60m (200') or less Indoor 120m (400') or less
Max. beam range (Approximation)	Outdoor 300m (1000') or less Indoor 300m (1000') or less	Outdoor 600m (2000') Indoor 600m (2000')
Response time	50msec. to 700msec. (Variable at pot)	
Supply voltage	10V to 30VDC (Non-polarity)	
Current consumption	53mA or less	80mA or less
Alarm output	Dry contact relay output form C Contact action : Interruption time + delay time (1 to 3 sec.) Contact capacity : 30V (AC/DC) 0.5A or less	
Tamper output	Dry contact relay N/C Action : Activated when cover is detached Contact capacity : 30V (AC/DC) 0.5A or less	
Alarm LED	Red LED (Receiver) ON : when an alarm is initiated.	
Attenuation LED	Red LED (Receiver) ON : when beam is attenuated.	
Functions	Monitor jack output, AGC circuit, Frost proof cover	
Ambient temperature range	-25°C to +60°C (-13°F to +140°F)	
Mounting positions	Indoor / Outdoor	
Wiring	Terminals	
Weight	Transmitter : 380g(13.3oz) Receiver : 400g(14oz)	
Appearance	PC resin(wine red)	

Please note : This sensor is designed to detect intrusion and to initiate an alarm, it is not a burglary-preventing device. TAKEX is not responsible for damage, injury or losses caused by accident, theft, Acts of God (including inductive surge by lightning), abuse, misuse, abnormal usage, faulty installation or improper maintenance.

LEAF 01-05R15-10

TAKEX

In Japan

Takenaka Engineering Co., Ltd.
83-1, Gojo-sotokan,
Higashino, Yamashina-ku,
Kyoto 607-8156, Japan
Tel : 81-75-501-6651
Fax : 81-75-593-3816
<http://www.takex-eng.co.jp/>

In the U.S.

Takex America Inc.
230E, Caribbean Drive
Sunnyvale,
CA 94086, U.S.A.
Tel : 408-747-0100
Fax : 408-734-1100
<http://www.takex.com>

In Australia

Takex America Inc.
Unit 16/35 Garden Road,
Clayton 3168 Victoria,
Australia
Tel : 03-9546-0533
Fax : 03-9547-9450

Takex America Inc.
Brisbane office : 1/50 Logan
Road, Woolloongabba
Queensland
4102, Australia
Tel : 07-3891-3344
Fax : 07-3891-3355

In the U.K.

Takex Europe Ltd.
Takex House, Aviator Court,
Wade Road, Basingstoke,
Hampshire, RG24 8PE, U.K.
Tel : (+44) 01256-475555
Fax : (+44) 01256-466268
<http://www.takexeurope.com>